



P/N 01999959

BARRIER FREE SURFACE WALL MOUNT PULL DOWN EYEWASH P/N 01040142

BARRIER FREE SURFACE WALL MOUNT PULL DOWN EYEWASH INSTALLATION INSTRUCTIONS

PARTS LIST:

- 1 – Pull Down Activation Eyewash (Item #1)
 - 1 – Spacer (Item #2)
 - 1 – Spring Clip Holder (Item #3)
 - 1 – Mounting Adapter (Item #4)
 - 1 – Pipe Nut and Washer (Item #5)
1. Determine mounting location for Barrier Free Surface Wall Mount Pull Down Eyewash.
 2. The Americans with Disabilities Act requires the eyewash heads, when in the activated position, to be 36" from the floor. Measure 36" from the floor and mark that location on the wall.
 3. The B.F. Surface Wall Mount Pull Down Eyewash has a 1/2" MNPT thread for the supply line. Drill a 7/8" diameter hole in the wall to accept the 1/2" pipe at the marked location. Also, at this time, drill a 1/8" diameter hole in the wall for the anti-vandal pin located on the eyewash valve. See mounting diagram on page 2 for hole locations.
 4. Secure the eyewash unit to the wall by passing the pipe nipple and roll pin through the wall and secure it to the wall with the pipe washer and nut. If necessary, use the mounting adapter to securely attach the unit to the wall. See diagram on page 2.
 5. Support the inlet supply line and attach supply line to unit.
 6. With the unit in the off position (eyewash heads rotated up and against the wall), measure approximately 15" from the inlet and mark the location. Attach the Spacer (Item #2) and Spring Clip Holder (Item #3) to the wall at the marked location. The spacer and spring clip holder must be in line with the vertical pipe on the eyewash unit so that, when in the closed position, the pipe is held by the spring clip holder. See diagram on page 2.
 7. Customer to supply the appropriate hardware for attaching the spacer (Item #2) and the Spring Clip Holder (Item #3) to the wall. The hole through the units accommodates a #10 diameter screw or bolt. The length of the screw or bolt should be a minimum of 2 1/16" plus the thickness of the wall. See diagram on page 2.
 8. Test unit with normal testing procedures.

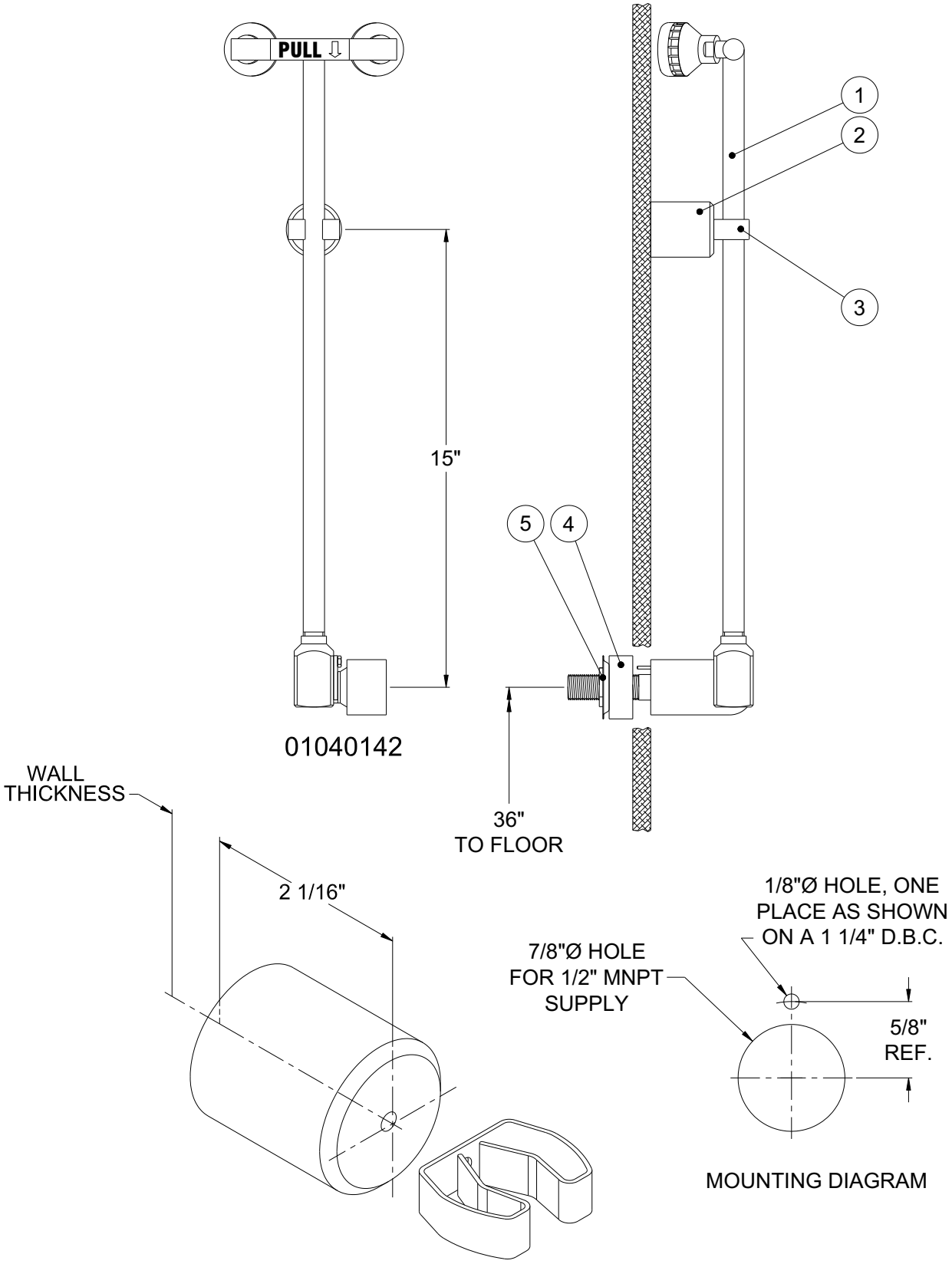

PROPOSITION 65

WARNING: This product can expose you to BPA, which is known to the State of California to cause birth defects or other reproductive harm. For more information go to www.P65Warnings.ca.gov.

WARRANTY STATEMENT

ENCON HEREBY DISCLAIMS ALL WARRANTIES EXPRESSED OR IMPLIED INCLUDING BUT NOT LIMITED TO WARRANTIES OF MERCHANTABILITY, FITNESS FOR A PARTICULAR PURPOSE, AND NON-INFRINGEMENT OF THIRD-PARTY RIGHTS, EXCEPT AS HEREINAFTER PROVIDED.

Encon Safety Products warrants that for one year from the date of purchase of any Encon products, the product will be free of defects in materials and workmanship if properly used and cared for or cleaned under normal conditions in accordance with Encon's use and care instructions and properly installed, if applicable, in accordance with Encon's installation instructions. With respect to the product, Encon's only obligation and purchaser's exclusive remedy under this warranty is to repair or replace such product; provided that:

1. Encon is notified of the defect within one year of shipment, and
2. the product is determined by Encon to be defective.

Encon requires proof of original ownership as proof of warranty coverage, and Encon must receive any claim under this Limited Warranty within one year of purchase of the product.

NOTWITHSTANDING ANYTHING TO THE CONTRARY CONTAINED HEREIN, ENCON SHALL NOT BE LIABLE FOR LOSS, DAMAGE, OR EXPENSE ARISING DIRECTLY OR INDIRECTLY AS A CONSEQUENCE OF USE OF THE EQUIPMENT WITH OTHER PRODUCTS OR FROM ANY OTHER CAUSE, INCLUDING ANY CONSEQUENTIAL, INCIDENTAL, SPECIAL OR EXEMPLARY DAMAGES, EXCEPT FOR ENCON'S OBLIGATION TO REPAIR OR REPLACE DEFECTIVE PRODUCTS AS EXPRESSLY PROVIDED IN THIS STATEMENT.

Replacement parts purchased from Encon are warranted for one year following the shipment of such replacement part, or until the expiration of the warranty period for the product, whichever is less. No warranty is given in connection with products that are altered without Encon's expressed written consent. The same warranty limitations and the obligations of Encon as set out herein above shall apply to replacement parts.

Encon's total liability arising out of this warranty (including, but not limited to, warranty claims) regardless of forum and regardless of whether such action or claim is based on tort, contract or otherwise will not exceed the total purchase price of the product.



6825 W. Sam Houston Pkwy. N
Houston, TX 77041
1-800-AT-ENCON / 1-800-283-6266
customerservice@enconsafety.com
<http://www.enconsafety.com>