

PRODUCT DESCRIPTION

Retrofit kits, designed to use on fountains with ABS bowls, protect eye/facewash heads from airborne contaminants.

Tools Required for Installation:

- | | |
|-----------------------------------|----------------------------|
| 1. Drill with 1/4" Bit | 4. Slotted Tip Screwdriver |
| 2. Adjustable Wrench | 5. 1/8" Allen Wrench |
| 3. Straight Edge 12" long minimum | |

COMPONENT PARTS LIST – See Diagram 1 below as reference

- | | | |
|---|---|---|
| 1 – Item #1 Eyewash Assembly (Kit #01120002) or Facewash Assembly (Kit #01120001) | 1 – Item #4 3/8"-24 Lock Nut | 2 – Item #9 3/16" Washer |
| 1 – Item #2 ABS Bowl Cover with Arm Extension | 1 – Item #5 Pull Open Coated Cable | 2 – Item #10 1/4" SS Shoulder Bolt |
| 1 – Item #3 Pushplate with Arm Extension | 1 – Item #6 Bowl Cover Mounting Bracket | 2 – Item #11 #10-32 x 1/2" lg. Pan Head Screw |
| | 1 – Item #7 1/2" NPT Pipe Nut | 2 – Item #12 #10-32 Lock Nut |
| | 1 – Item #8 Hinge Pin with Snap Ring | |

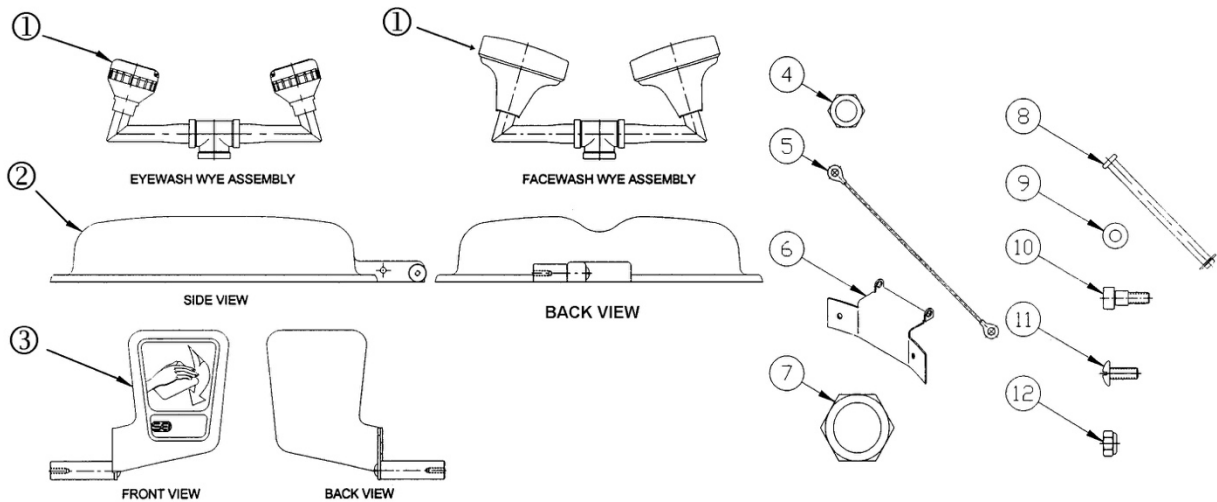

DIAGRAM 1

ASSEMBLY AND INSTALLATION INSTRUCTIONS

1. Remove eyewash or facewash assembly from existing eye/facewash station and discard.
2. Remove lock nut and pushplate from existing eye/facewash station and discard.
3. Place a straight edge on the ABS bowl in the position as shown in Diagram 2 below. Align the edge so that it is in-line with the centers of both the supply pipe and drain on the bowl. Mark that location on the top edge of the bowl.

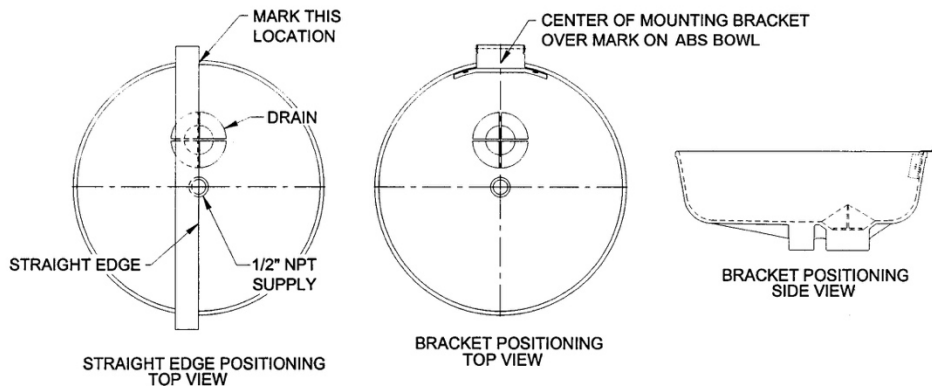

DIAGRAM 2

ASSEMBLY AND INSTALLATION INSTRUCTIONS - continued

1. Place bowl cover mounting bracket (item #6) on the top edge of the ABS bowl as shown in **Diagram 2** (page 1). The middle of the mounting bracket should be in-line with the mark on the top of the bowl.
2. Mark the locations of the mounting holes of the mounting bracket, remove the bracket, and drill the marked hole locations using a 1/4" drill bit.
3. Attach mounting bracket to bowl with two (2) #10-32 x 1/2" lg. pan head screws (item #11) and two (2) #10-32 lock nuts (item #12).
4. Remove snap ring from hinge pin (item #8). Place one (1) 3/16" washer (item #9) on hinge pin. Place ABS bowl cover (item #2) over mounting bracket so that the hinge pin holes are in-line with the holes in the mounting bracket. Slide hinge pin through ABS bowl cover and mounting bracket. Place one (1) 3/16" washer on hinge pin and reattach snap ring. See **Diagram 3** below.
5. Attach pushplate with extension arm (item #3) to the stem of ball valve using one (1) 3/8"-24 lock nut (item #4).
6. With valve in the closed position, attach the pull open coated cable (item #5) to the extension arms of the pushplate (item #3) and bowl cover (item #2) using two (2) 1/4" shoulder bolts (item #10). Tighten shoulder bolts with a 1/8" Allen wrench. See **Diagram 3**.
7. Manually open bowl cover by lifting it by the front edge and pivoting it toward the rear. Screw the 1/2" NPT pipe nut (item #7) onto the bowl supply pipe. Tighten the pipe nut until it contacts the bowl.
8. Thread eyewash or facewash assembly (item #1) to supply pipe of the reservoir. Hand tightened until snug. Once snug, rotate back until eyewash heads are aligned with push plate (when in off position). **CAUTION: Do not over tighten. Do not use pipe sealant.**
9. If required, unscrew pipe nut (item #7) until it contacts the bottom of the eye/facewash assembly, and tighten to ensure the eye/facewash remains in the correct position.
10. Test the eye/facewash assembly by activating the pushplate.
11. The bowl cover should open and remain in the open position after closing the valve. The bowl cover should be manually returned to sit atop of the bowl after the pushplate/valve is returned to the off position.
12. The bowl cover can be opened for maintenance without activating the pushplate.

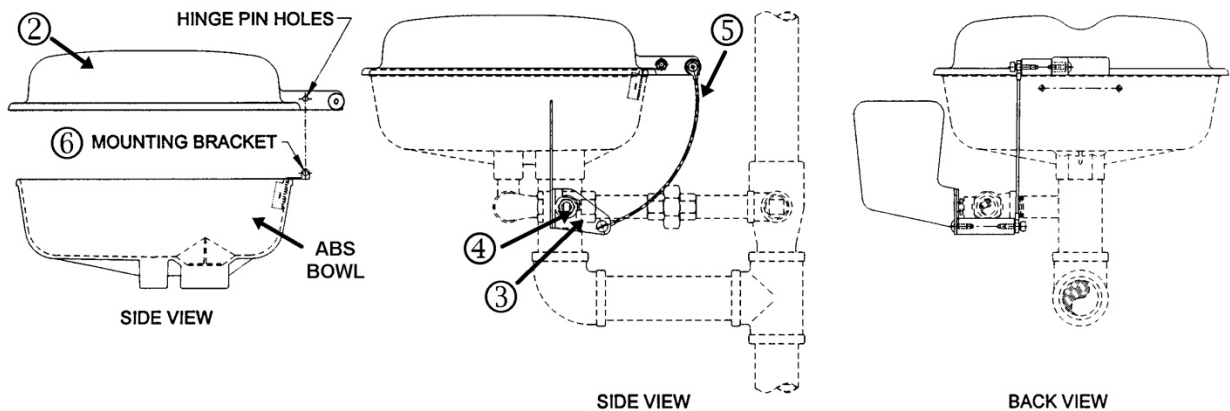

DIAGRAM 3

PROPOSITION 65

WARNING: This product can expose you to BPA, which is known to the State of California to cause birth defects or other reproductive harm. For more information go to www.P65Warnings.ca.gov.

WARRANTY STATEMENT

ENCON HEREBY DISCLAIMS ALL WARRANTIES EXPRESSED OR IMPLIED INCLUDING BUT NOT LIMITED TO WARRANTIES OF MERCHANTABILITY, FITNESS FOR A PARTICULAR PURPOSE, AND NON-INFRINGEMENT OF THIRD-PARTY RIGHTS, EXCEPT AS HEREINAFTER PROVIDED.

Encon Safety Products warrants that for one year from the date of purchase of any Encon products, the product will be free of defects in materials and workmanship if properly used and cared for or cleaned under normal conditions in accordance with Encon's use and care instructions and properly installed, if applicable, in accordance with Encon's installation instructions. With respect to the product, Encon's only obligation and purchaser's exclusive remedy under this warranty is to repair or replace such product; provided that:

1. Encon is notified of the defect within one year of shipment, and
2. the product is determined by Encon to be defective.

Encon requires proof of original ownership as proof of warranty coverage, and Encon must receive any claim under this Limited Warranty within one year of purchase of the product.

NOTWITHSTANDING ANYTHING TO THE CONTRARY CONTAINED HEREIN, ENCON SHALL NOT BE LIABLE FOR LOSS, DAMAGE, OR EXPENSE ARISING DIRECTLY OR INDIRECTLY AS A CONSEQUENCE OF USE OF THE EQUIPMENT WITH OTHER PRODUCTS OR FROM ANY OTHER CAUSE, INCLUDING ANY CONSEQUENTIAL, INCIDENTAL, SPECIAL OR EXEMPLARY DAMAGES, EXCEPT FOR ENCON'S OBLIGATION TO REPAIR OR REPLACE DEFECTIVE PRODUCTS AS EXPRESSLY PROVIDED IN THIS STATEMENT.

Replacement parts purchased from Encon are warranted for one year following the shipment of such replacement part, or until the expiration of the warranty period for the product, whichever is less. No warranty is given in connection with products that are altered without Encon's expressed written consent. The same warranty limitations and the obligations of Encon as set out herein above shall apply to replacement parts.

Encon's total liability arising out of this warranty (including, but not limited to, warranty claims) regardless of forum and regardless of whether such action or claim is based on tort, contract or otherwise will not exceed the total purchase price of the product.



6825 W. Sam Houston Pkwy. N
Houston, TX 77041
1-800-AT-ENCON / 1-800-283-6266
customerservice@enconsafety.com
<http://www.enconsafety.com>