

PRODUCT DESCRIPTION

Yellow transportation cart for use with Encon Safety Product's portable Self-Contained Gravity Fed Eyewash and Aquarion[®].

COMPONENT LIST

- | | |
|--|--|
| <ol style="list-style-type: none"> 1. Base Plate (1) 2. Front Leg (2) 3. Upper Support (1) 4. Rear Leg (2) 5. Upper Frame (1) 6. Lower Support (1) 7. Axle (1) 8. Locking Caster (2) 9. 10" Wheel (2) | <ol style="list-style-type: none"> 10. Bolt, 1/4"-20 x 2-1/2"lg (4) 11. Bolt, 1/4"-20 x 1-1/2"lg (10) 12. Bolt, 1/4"-20 x 3/4"lg (16) 13. Lock Nut 1/4"-20 (26) 14. Flat Washer 5/8" (4) 15. Cotter Pin (2) 16. Stop Plate (1) 17. Hand Grip (2) 18. Axle Support (2) |
|--|--|

TOOLS REQUIRED

1. Hammer
2. Pliers
3. 7/16" Wrench (2)

INSTALLATION INSTRUCTIONS

Step 1: Attach Stop Plate to Base Plate with Bolt and Lock Nuts (ref FIG #1).

Step 2: Insert post on Locking Caster in base plate, until caster locks. Note orientation on base plate. Repeat step on other side (ref FIG #1).

Step 3: Attach Axle Support to Base Plate, using Bolt and Lock Nut. Repeat step on other side (ref Fig #1).

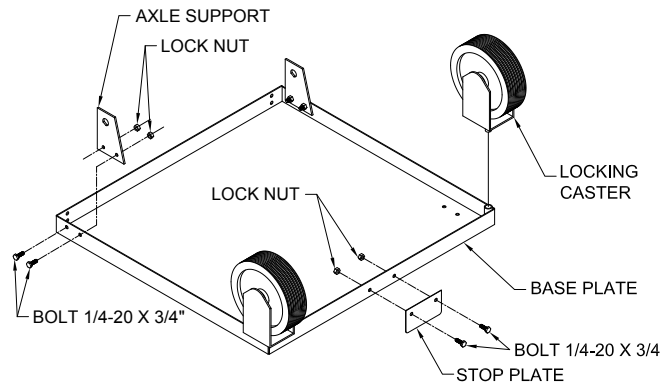

Fig #1

Step 4: Insert Axle through two Axle Supports (ref Fig 2)

Step 5: Place 10" Wheel with Flat Wash on each wide on wheel. Repeat step on other side (ref FIG #2).

Step 6: Install Cotter Pin through hole on Axle to secure 10" wheel. Repeat step on other side (ref FIG #2)

(cont page 2)

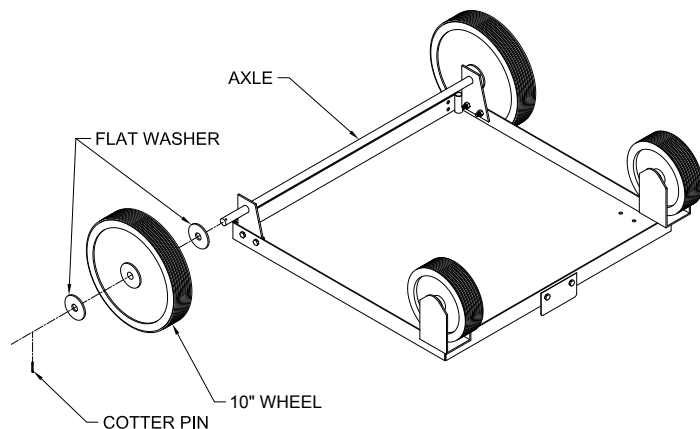

Fig #2

Step 7: Install Front Leg to base assembly using two Bolts 1/4"-20 x 3/4" and locking nuts (ref Fig #3).

Step 8: Install Rear Leg to base assembly using two Bolts 1/4"-20 x 3/4" and locking nuts. Do not attach front leg to rear leg (ref Fig #3).

Step 9: Repeat steps 7 and 8 for other side of unit.

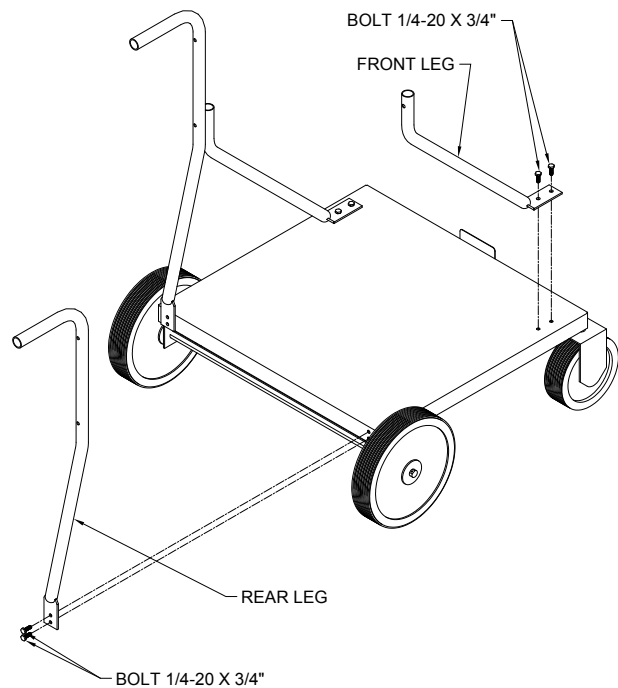

Fig #3

Step 10: Insert Upper Frame into mating hole on Front Leg. Secure Upper Frame to Front Legs using Bolt 1/4"-20 x 2-1/2" and Lock Nut (ref Fig #4).

Step 11: Slip Hand Grip onto Rear Leg, two places (ref Fig #4).

Step 12: Attach Upper Support to Upper Frame using four Bolt 1/2"-20 x 1-1/2 and Lock Nuts (ref Fig #4).
(cont page 3)

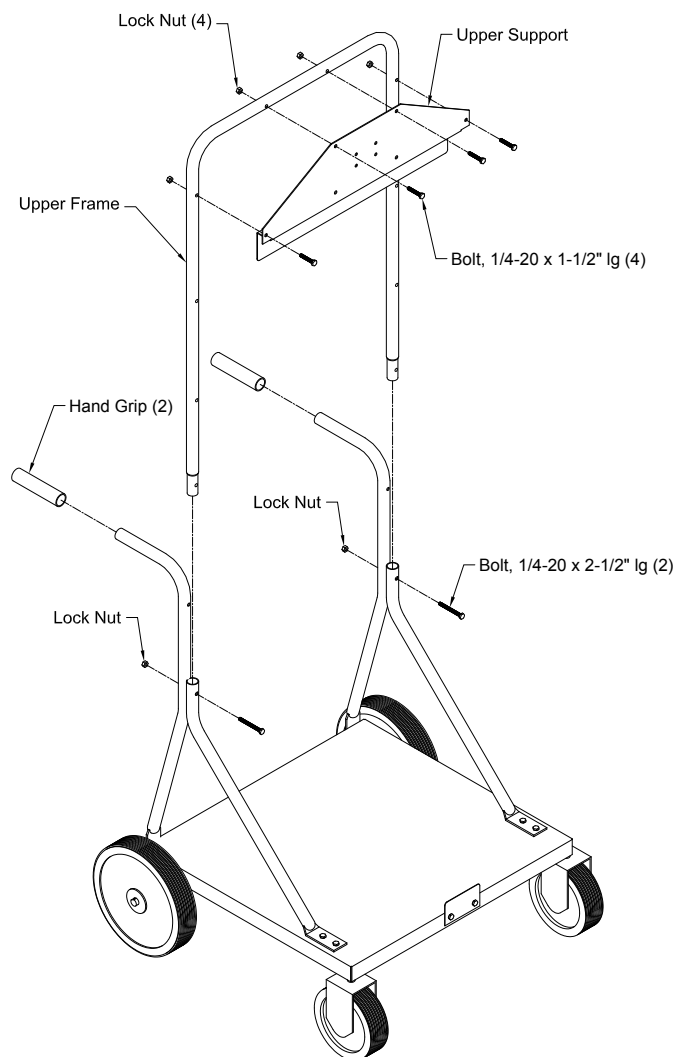

Fig #4

(Steps 13 and 14 for Gravity Fed Eyewash only, Ref Fig #5)

Step 13: Attach short surface of Lower Support to Upper Frame using two bolts $\frac{1}{4}$ "-20 x 2-1/2" lg and locking nuts as shown. Note orientation and location of Lower support.

Step 14: Attach J-Hook to hole in Upper Support using two bolts $\frac{1}{4}$ "-20 x $\frac{3}{4}$ " lg as shown. J-Hook supplied with Gravity Fed Eyewash.

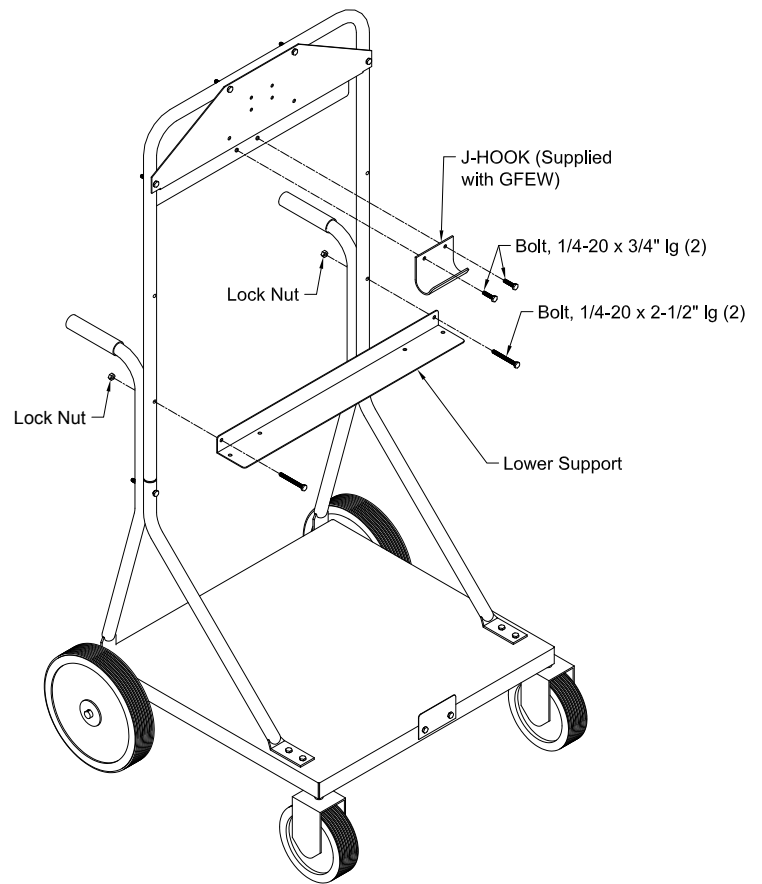

Fig #5
(Gravity Fed Eyewash only)

(Steps 15 and 16 for Aquarion® mounting only)

Step 13: Attach long surface of Lower Support to Upper Frame using two bolts $\frac{1}{4}$ "-20 x 1-1/2" lg as shown. Note orientation and location of Lower support.

Step 14: Attach Aquarion mounting plate to holes in Upper and Lower Support using four bolts $\frac{1}{4}$ "-20 x 1-1/2 and locking nuts as shown. Mounting Plate supplied with Aquarion eyewash station.

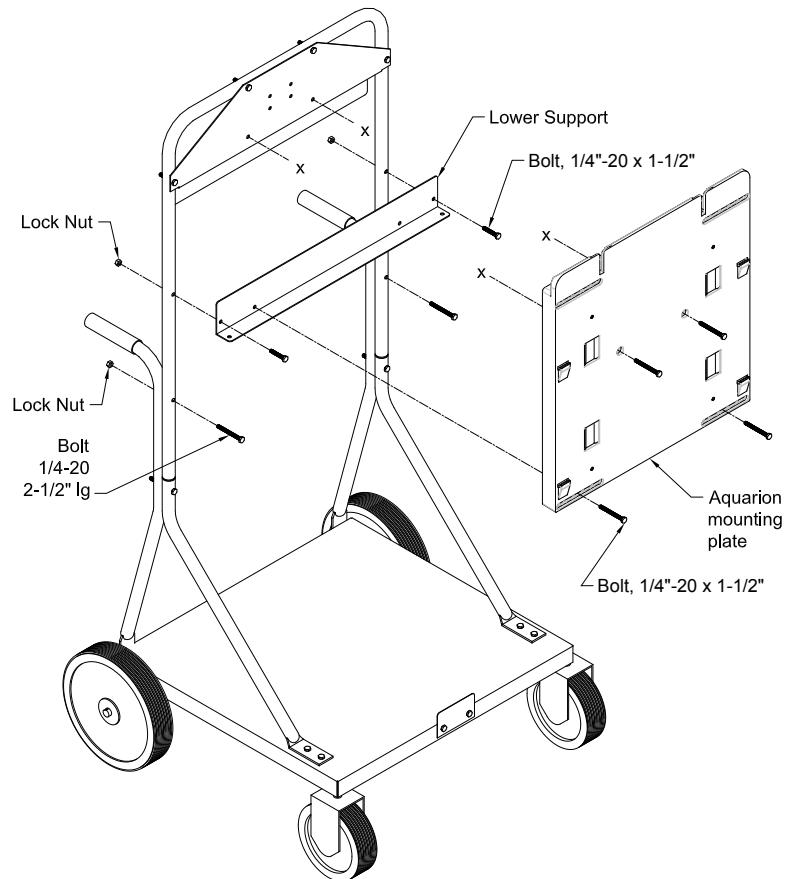

Fig #6
(Aquarion mounting only)

GENERAL INFORMATION

Following are requirements of ANSI Z358.1 for Emergency Eyewash and Shower Equipment. A complete copy of this standard may be purchased from the International Safety Equipment Association.

TRAINING

All employees who might be exposed to hazardous material shall be instructed in the location and proper use of emergency shower and eye/facewash units. Experiences have shown that initial first-aid treatment for irritants should be to wash the eyes and face for 15 minutes prior to medical treatment. It is important to hold the eyelids open and roll the eyes so water will flow on all surfaces and in the folds surrounding the eyes.

WARRANTY STATEMENT

ENCON HEREBY DISCLAIMS ALL WARRANTIES EXPRESSED OR IMPLIED INCLUDING BUT NOT LIMITED TO WARRANTIES OF MERCHANTABILITY, FITNESS FOR A PARTICULAR PURPOSE, AND NON-INFRINGEMENT OF THIRD-PARTY RIGHTS, EXCEPT AS HEREINAFTER PROVIDED.

Encon Safety Products warrants that for one year from the date of purchase of any Encon products, the product will be free of defects in materials and workmanship if properly used and cared for or cleaned under normal conditions in accordance with Encon's use and care instructions and properly installed, if applicable, in accordance with Encon's installation instructions. With respect to the product, Encon's only obligation and purchaser's exclusive remedy under this warranty is to repair or replace such product; provided that:

1. Encon is notified of the defect within one year of shipment, and
2. the product is determined by Encon to be defective.

Encon requires proof of original ownership as proof of warranty coverage, and Encon must receive any claim under this Limited Warranty within one year of purchase of the product.

NOTWITHSTANDING ANYTHING TO THE CONTRARY CONTAINED HEREIN, ENCON SHALL NOT BE LIABLE FOR LOSS, DAMAGE, OR EXPENSE ARISING DIRECTLY OR INDIRECTLY AS A CONSEQUENCE OF USE OF THE EQUIPMENT WITH OTHER PRODUCTS OR FROM ANY OTHER CAUSE, INCLUDING ANY CONSEQUENTIAL, INCIDENTAL, SPECIAL OR EXEMPLARY DAMAGES, EXCEPT FOR ENCON'S OBLIGATION TO REPAIR OR REPLACE DEFECTIVE PRODUCTS AS EXPRESSLY PROVIDED IN THIS STATEMENT.

Replacement parts purchased from Encon are warranted for one year following the shipment of such replacement part, or until the expiration of the warranty period for the product, whichever is less. No warranty is given in connection with products that are altered without Encon's expressed written consent. The same warranty limitations and the obligations of Encon as set out herein above shall apply to replacement parts.

Encon's total liability arising out of this warranty (including, but not limited to, warranty claims, regardless of forum and regardless of whether such action or claim is based on tort, contract or otherwise will not exceed the total purchase price of the product.



6825 W. Sam Houston Pkwy. N (77041)
P.O. Box 3826 • Houston, Texas (77253)
(713) 466-1449 • Fax (713) 466-1819
1-800-AT-ENCON / 1-800-283-6266

E-Mail: customerservice@enconsafety.com

Website: www.enconsafety.com